

Features

- Small Body Outline Dimensions:
0.039" x 0.024" (1.0 mm x 0.60 mm)
- Protects one I/O or power line
- Low Clamping Voltage
- Ultra Low Capacitance:0.5pF
- Working Voltage: 5 V
- Low Leakage Current
- Response Time is Typically < 1 ns

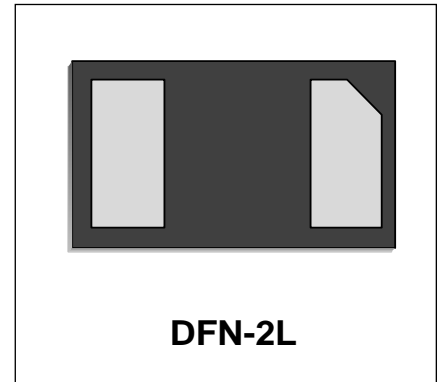

IEC COMPATIBILITY (EN61000-4)

- IEC 61000-4-2 (ESD) $\pm 15\text{kV}$ (air), $\pm 8\text{kV}$ (contact)
- IEC 61000-4-4 (EFT) 40A (5/50ns)

Mechanical Characteristics

- DFN-2L package
- Molding compound flammability rating:
UL 94V-0
- Marking: Marking Code
- Packaging: Tape and Reel per EIA 481
- RoHS Compliant

Applications

- Laptop Computers
- Cellular Phones
- Digital Cameras
- Personal Digital Assistants (PDAs)

Schematic & PIN Configuration

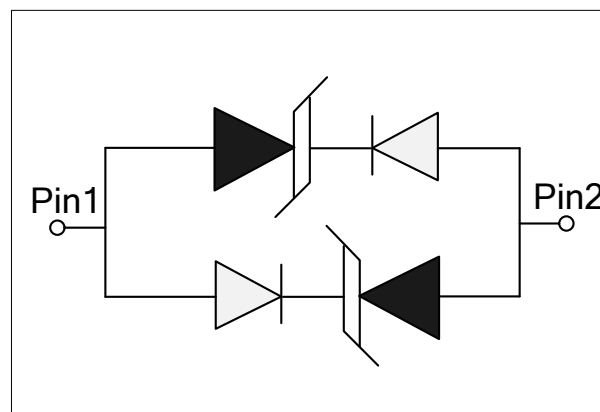

Absolute Maximum Rating			
Rating	Symbol	Value	Units
Electrostatic discharge Voltage (See Note1 ,2)	V _{ESD}	8KV (contact)	Volts
		15KV (air)	
Operating Temperature	T _J	-55 to + 125	°C
Storage Temperature	T _{STG}	-55 to +150	°C

Electrical Parameters (T=25°C)

Symbol	Parameter
I _{PP}	Maximum Reverse Peak Pulse Current
V _C	Clamping Voltage @ I _{PP}
V _{RWM}	Working Peak Reverse Voltage
I _R	Maximum Reverse Leakage Current @ V _{RWM}
V _{BR}	Breakdown Voltage @ I _T
I _T	Test Current

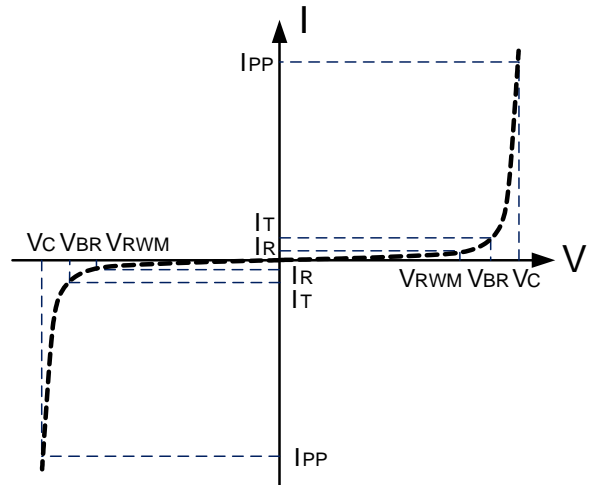

Electrical Characteristics

DW05DUCF-B-01-E						
Parameter	Symbol	Conditions	Minimum	Typical	Maximum	Units
Reverse Stand-Off Voltage	V _{RWM}				5.0	V
Reverse Breakdown Voltage	V _{BR}	I _T =1mA	6.0			V
Reverse Leakage Current	I _R	V _{RWM} =5V, T=25°C			1	µA
Clamping Voltage	V _C	I _{PP} =1A, t _p =8/20µs		8.5	12.5	V
Junction Capacitance	C _j	V _R = 0V, f= 1MHz		0.5	0.8	pF

Note1: ESD Pulse Waveform according to IEC 61000-4-2. see Table1 and Figure4.

Note2: ESD tests Setup see Figure 5.

Typical Characteristics

Figure 1: Power Derating Curve

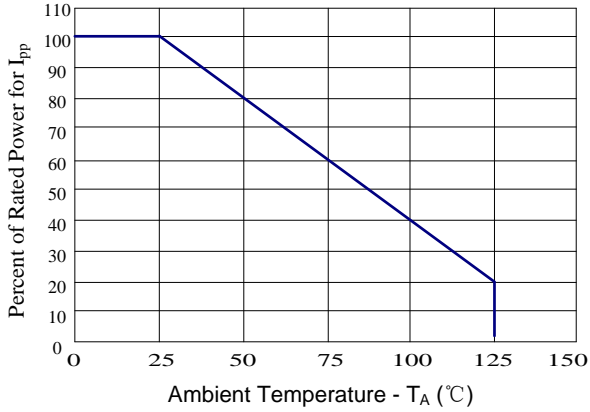

Figure 2: Insertion Loss

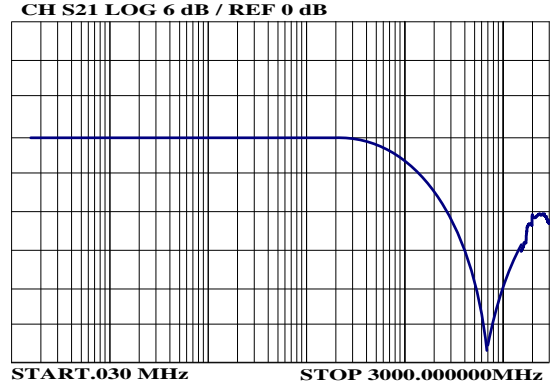

Figure 3: Normalized Junction Capacitance vs. Reverse Voltage

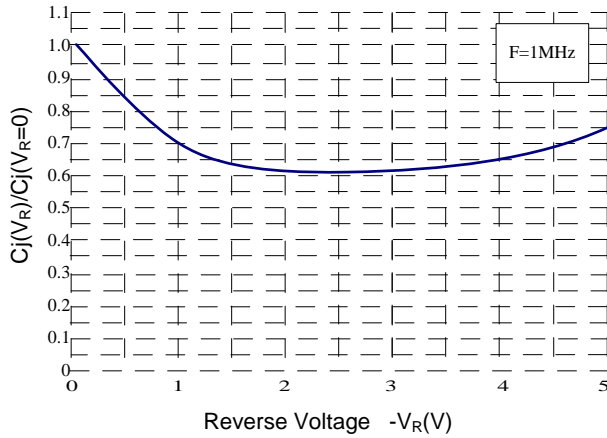

Table 1. IEC 61000-4-2 Discharge Parameters

Level	First Peak Current (A)	Peak Current at 30 ns (A)	Peak Current at 60 ns (A)	Test Voltage (Contact Discharge) (kV)	Test Voltage (Air Discharge) (kV)
1	7.5	4	2	2	2
2	15	8	4	4	4
3	22.5	12	6	6	8
4	30	16	8	8	15

Figure 4. IEC 61000-4-2 Waveform

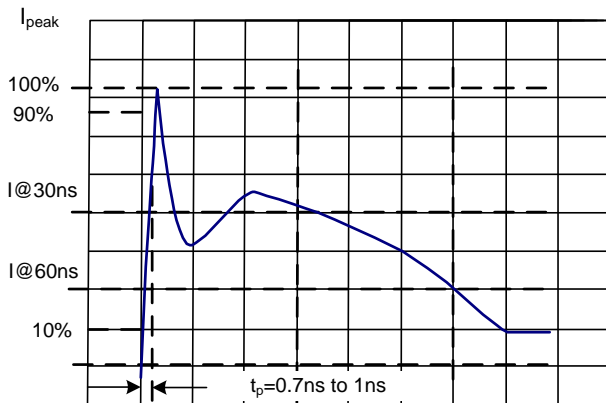
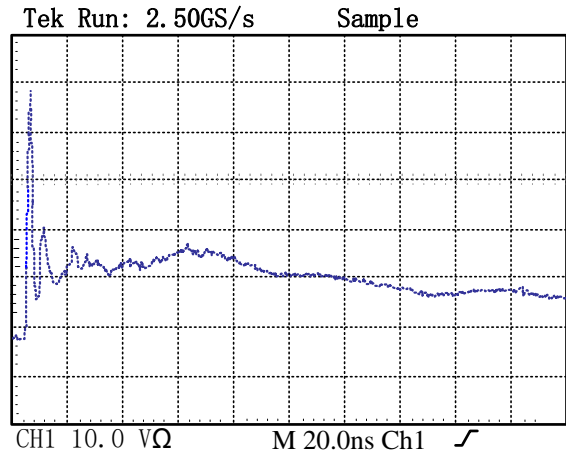

Figure 5: ESD Clamping(8kV Contact per IEC 61000-4-2)



Outline Drawing –DFN-2L

PACKAGE OUTLINE

BOTTOM VIEW

DFN-2L

SYMB	MILIMETER		
	MIN	NOM	MAX
OL			
A	0.45	0.50	0.55
A1	0	0.02	0.05
b	0.45	0.50	0.55
C	0.12	0.15	0.18
D	0.95	1.00	1.05
e	0.65BSC		
E	0.55	0.60	0.65
L	0.20	0.25	0.30
L1	0.05REF		
h	0.07	0.12	0.17

Land Pattern

Marking Codes

Part Number	Marking Code
DW05DUCF-B-01-E	5 T

Package Information

Qty: 10k/Reel